

JEE MAIN 2016

ONLINE EXAMINATION

DATE : 09-04-2016

SUBJECT : PHYSICS

TEST PAPER
WITH SOLUTIONS & ANSWER KEY





RESONANCE EDUVENTURES LTD.

CORPORATE OFFICE : CG TOWER, A-46 & 52, IPIA, NEAR CITY MALL, JHALAWAR ROAD, KOTA (RAJ.) - 324005

REG. OFFICE : J-2, JAWAHAR NAGAR, MAIN ROAD, KOTA (RAJ.)-324005 | PH. NO.: +91-744-3192222 | FAX NO. : +91-022-39167222

PH.NO. : +91-744-3012222, 6635555 | TO KNOW MORE : SMS RESO AT 56677

WEBSITE : WWW.RESONANCE.AC.IN | E-MAIL : CONTACT@RESONANCE.AC.IN | CIN : U80302RJ2007PLC024029

Toll Free : 1800 258 5555  08003 444 888  facebook.com/ResonanceEdu  twitter.com/ResonanceEdu  www.youtube.com/resowatch  blog.resonance.ac.in

THIS SOLUTION WAS DOWNLOAD FROM RESONANCE JEE Main 2016 SOLUTION PORTAL

JEE (Advanced)

Selections
(from 2002-2015)

23182

(YCCP: 14864 | DLP+eLP: 8318)

Selections @ 2015

4124

(YCCP: 2570 | DLP+eLP: 1554)

*Highest selections in JEE (Adv) 2015
in India from any single institute of Kota*

JEE (Main)

Selections
(from 2009-2015)

93915

(YCCP: 66288 | DLP+eLP: 27627)

Selections @ 2015

25542

(YCCP: 18816 | DLP+eLP: 6726)

*Highest selections in JEE (Main) 2015
in India from any single institute of Kota*

For Classes: XI, XII & XII+

Target: JEE (Main + Advanced) | JEE (Main) | Board/ IJSO/ NTSE

**Resonance National Entrance Test
(ResoNET)**

8th & 15th May, 2016

Toll Free: 1800 258 5555

1. Two particles are performing simple harmonic motion in a straight line about the same equilibrium point. The amplitude and time period for both particles are same and equal to A and T , respectively. At time $t = 0$ one particle has displacement A while the other one has displacement $\frac{-A}{2}$ and they are moving towards each other. If they cross each other at time t , then t is :

- (1) $\frac{T}{4}$ (2) $\frac{5T}{6}$ (3) $\frac{T}{3}$ (4) $\frac{T}{6}$

Ans. (4)

Sol.

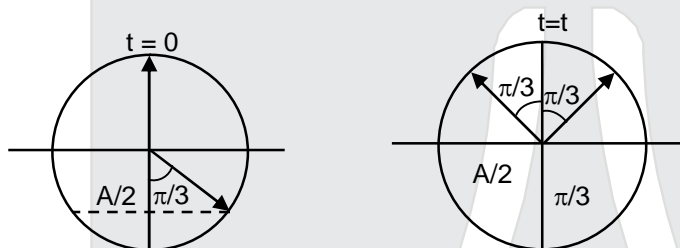

$$t = \frac{\pi}{3\omega} = \frac{T}{6}$$

2. To find the focal length of a convex mirror, a student records the following data :

Object pin	Convex Lens	Convex Mirror	Image Pin
22.2 cm	32.2cm	45.8 cm	71.2 cm

The focal length of the convex lens is f_1 and that of mirror is f_2 . Then taking index correction to be negligibly small, f_1 and f_2 are close to :

- (1) $f_1 = 15.6$ cm $f_2 = 25.4$ cm
 (2) $f_1 = 7.8$ cm $f_2 = 12.7$ cm
 (3) $f_1 = 7.8$ cm $f_2 = 25.4$ cm
 (4) $f_1 = 12.7$ cm $f_2 = 7.8$ cm

Ans. (2)

Sol. For convex lens

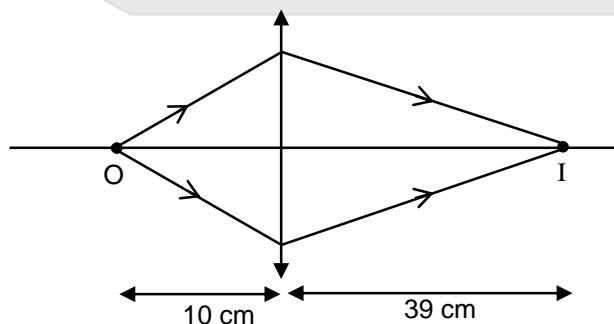

$$u = -10 \text{ cm}$$

$$v = 39 \text{ cm}$$

RESONANCE EDUVENTURES LTD.

CORPORATE OFFICE : CG TOWER, A-46 & 52, IPIA, NEAR CITY MALL, JHALAWAR ROAD, KOTA (RAJ.) - 324005

REG. OFFICE : J-2, JAWAHAR NAGAR, MAIN ROAD, KOTA (RAJ.)-324005 | PH. NO.: +91-744-3192222 | FAX NO. : +91-022-39167222

PH.NO. : +91-744-3012222, 6635555 | TO KNOW MORE : SMS RESO AT 56677

WEBSITE : WWW.RESONANCE.AC.IN | E-MAIL : CONTACT@RESONANCE.AC.IN | CIN : U80302RJ2007PLC024029

Toll Free : 1800 258 5555 08003 444 888 facebook.com/ResonanceEdu twitter.com/ResonanceEdu www.youtube.com/resowatch blog.resonance.ac.in

$$f_1 = \frac{uv}{u-v}$$

$$= \frac{390}{49} = 7.8 \text{ cm}$$

For convex mirror

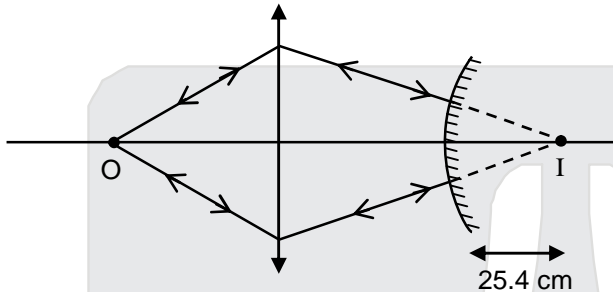

$$R = 25.4 \text{ cm}$$

$$f_2 = 12.7 \text{ cm}$$

3. Figure shows elliptical path abcd of a planet around the sun S such that the area of triangle csa is $\frac{1}{4}$ the area of the ellipse. (See figure) With db as the semi major axis, and ca as the semi minor axis. If t_1 is the time taken for planet to go over path abc and t_2 for path taken over cda then :

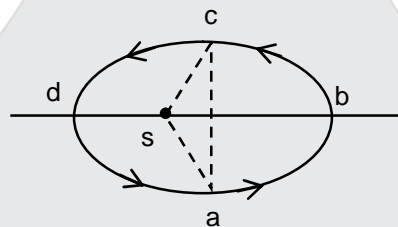

- (1) $t_1 = 3t_2$ (2) $t_1 = t_2$ (3) $t_1 = 2t_2$ (4) $t_1 = 4t_2$

Ans. (1)

Sol. Total area = A

$$\text{Area of sabc} = \frac{3A}{4}$$

$$\text{Area of sadc} = \frac{A}{4}$$

$$\frac{3A}{4t_1} = \frac{A}{4t_2} \Rightarrow t_1 = 3t_2$$

RESONANCE EDUVENTURES LTD.

CORPORATE OFFICE : CG TOWER, A-46 & 52, IPIA, NEAR CITY MALL, JHALAWAR ROAD, KOTA (RAJ.) - 324005

REG. OFFICE : J-2, JAWAHAR NAGAR, MAIN ROAD, KOTA (RAJ.)-324005 | PH. NO.: +91-744-3192222 | FAX NO. : +91-022-39167222

PH.NO. : +91-744-3012222, 6635555 | TO KNOW MORE : SMS RESO AT 56677

WEBSITE : WWW.RESONANCE.AC.IN | E-MAIL : CONTACT@RESONANCE.AC.IN | CIN : U80302RJ2007PLC024029

Toll Free : 1800 258 5555 08003 444 888 facebook.com/ResonanceEdu twitter.com/ResonanceEdu www.youtube.com/resowatch blog.resonance.ac.in

4. A simple pendulum made of a bob of mass m and a metallic wire of negligible mass has time period $2s$ at $T = 0^\circ\text{C}$. If the temperature of the wire is increased and the corresponding change in its time period is plotted against its temperature, the resulting graph is a line of slope S . If the coefficient of linear expansion of metal is α then the value of S is :

- (1) $\frac{1}{\alpha}$ (2) 2α (3) $\frac{\alpha}{2}$ (4) α

Ans. (4)

Sol. $t_0 = 2 = 2\pi\sqrt{\frac{\ell_0}{g}}$
 $t = 2\pi\sqrt{\frac{\ell_0(1+\alpha T)}{g}} = 2(1+\alpha T)^{1/2} = 2 + \alpha T$

$t - t_0 = \alpha T \Rightarrow \Delta t = \alpha T$

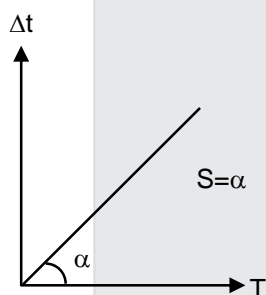

5. The ratio of work done by an ideal monatomic gas to the heat supplied to it in an isobaric process is :

- (1) $\frac{3}{2}$ (2) $\frac{2}{3}$ (3) $\frac{3}{5}$ (4) $\frac{2}{5}$

Ans. (4)

Sol. $\Delta w = P\Delta V = nR\Delta T$

$\Delta Q = nC_p \Delta T = \frac{5}{2} nR\Delta T$

$\frac{\Delta w}{\Delta Q} = \frac{2}{5}$

RESONANCE EDUVENTURES LTD.

CORPORATE OFFICE : CG TOWER, A-46 & 52, IPIA, NEAR CITY MALL, JHALAWAR ROAD, KOTA (RAJ.) - 324005

REG. OFFICE : J-2, JAWAHAR NAGAR, MAIN ROAD, KOTA (RAJ.)-324005 | PH. NO.: +91-744-3192222 | FAX NO. : +91-022-39167222

PH.NO. : +91-744-3012222, 6635555 | TO KNOW MORE : SMS RESO AT 56677

WEBSITE : WWW.RESONANCE.AC.IN | E-MAIL : CONTACT@RESONANCE.AC.IN | CIN : U80302RJ2007PLC024029

Toll Free : 1800 258 5555 08003 444 888 facebook.com/ResonanceEdu twitter.com/ResonanceEdu www.youtube.com/resowatch blog.resonance.ac.in

6. An unknown transistor needs to be identified as npn or pnp type .A multimeter, with +ve and –ve terminals, is used to measure resistance between different terminals transistor. If terminal 2 is the base of the transistor then which of the following is correct for a pnp transistor ?
- (1) +ve terminal 3, –ve terminal 2, resistance high
 - (2) +ve terminal 2, –ve terminal 3, resistance low
 - (3) +ve terminal 1, –ve terminal 2, resistance high
 - (4) +ve terminal 2, –ve terminal 1, resistance high

Ans. (4)
Sol.

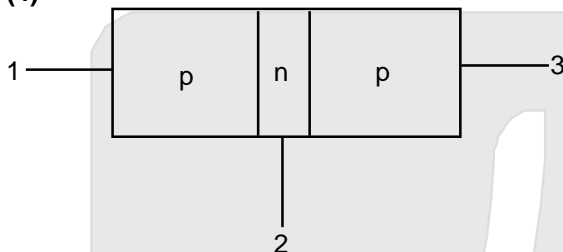

when pn junction is forward biased resistance is low. When pn junction reverse biased resistance is high

7. A uniformly tapering conical wire is made from a material of Young's modulus Y and has a normal, unextended length L . The radii, at the upper and lower ends of this conical wire, have values R and $3R$, respectively. The upper end of the wire is fixed to a rigid support and a mass M is suspended from its lower end. The equilibrium extended length, of this wire, would equal

- (1) $L \left(1 + \frac{1}{3} \frac{Mg}{\pi Y R^2} \right)$
- (2) $L \left(1 + \frac{2}{3} \frac{Mg}{\pi Y R^2} \right)$
- (3) $L \left(1 + \frac{1}{9} \frac{Mg}{\pi Y R^2} \right)$
- (4) $L \left(1 + \frac{2}{9} \frac{Mg}{\pi Y R^2} \right)$

Ans. (1)
Sol.

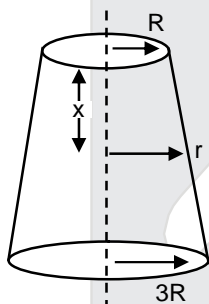

$$\frac{r - R}{x} = \frac{3R - R}{L} \Rightarrow r = R \left(1 + \frac{2x}{L} \right) ; Y = \frac{Mg}{\pi R^2 \frac{dL}{dx}}$$

$$dL = \frac{Mg}{\pi R^2} \frac{dx}{\left(1 + \frac{2x}{L} \right)^2}$$

$$\Delta L = \frac{Mg}{Y \pi R^2} \int_0^L \frac{dx}{\left(1 + \frac{2x}{L} \right)^2} = \frac{MgL}{3\pi R^2 Y} ; L' = L + \Delta L = L \left(1 + \frac{1}{3} \frac{Mg}{\pi R^2 Y} \right)$$

RESONANCE EDUVENTURES LTD.

CORPORATE OFFICE : CG TOWER, A-46 & 52, IPIA, NEAR CITY MALL, JHALAWAR ROAD, KOTA (RAJ.) - 324005

REG. OFFICE : J-2, JAWAHAR NAGAR, MAIN ROAD, KOTA (RAJ.)-324005 | PH. NO.: +91-744-3192222 | FAX NO. : +91-022-39167222

PH.NO. : +91-744-3012222, 6635555 | TO KNOW MORE : SMS RESO AT 56677

WEBSITE : WWW.RESONANCE.AC.IN | E-MAIL : CONTACT@RESONANCE.AC.IN | CIN : U80302RJ2007PLC024029

Toll Free : 1800 258 5555 | 08003 444 888 | [facebook.com/ResonanceEdu](https://www.facebook.com/ResonanceEdu) | twitter.com/ResonanceEdu | www.youtube.com/resowatch | blog.resonance.ac.in

8. A cubical block of side 30cm is moving with velocity 2ms^{-1} on a smooth horizontal surface. The surface has a bump at point O as shown in figure. The angular velocity (in rad/s) of the block immediately after it hits the bump, is :

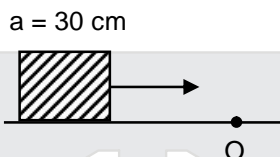

- (1) 9.4 (2) 6.7 (3) 5.0 (4) 13.3

Ans. (3)

Sol. Using conservation of angular momentum

$$mv \frac{a}{2} = \frac{2}{3} ma^2 \omega \Rightarrow \omega = \frac{3v}{4a} = 5 \text{ rad/s}$$

9. In Young's double slit experiment, the distance between slits and the screen is 1.0 m and monochromatic light of 600 nm is being used. A person standing near the slits is looking at the fringe pattern. When the separation between the slits is varied, the interference pattern disappears for a particular distance d_0 between the slits. If the angular resolution of the eye is $\frac{1^\circ}{60}$ the value of d_0 is

close to

- (1) 2 mm (2) 1 mm (3) 3mm (4) 4 mm

Ans. (1)

Sol. Angular fringe width $\theta = \frac{\beta}{D} = \frac{\lambda}{d}$

$$\frac{\lambda}{d_0} = \frac{1^\circ}{60} = \frac{\pi}{180 \times 60}$$

$$d_0 = \lambda \left(\frac{180 \times 60}{\pi} \right)$$

$$= 2 \times 10^{-3} \text{ m} = 2 \text{ mm.}$$





RESONANCE EDUVENTURES LTD.

CORPORATE OFFICE : CG TOWER, A-46 & 52, IPIA, NEAR CITY MALL, JHALAWAR ROAD, KOTA (RAJ.) - 324005

REG. OFFICE : J-2, JAWAHAR NAGAR, MAIN ROAD, KOTA (RAJ.)-324005 | PH. NO.: +91-744-3192222 | FAX NO. : +91-022-39167222

PH.NO. : +91-744-3012222, 6635555 | TO KNOW MORE : SMS RESO AT 56677

WEBSITE : WWW.RESONANCE.AC.IN | E-MAIL : CONTACT@RESONANCE.AC.IN | CIN : U80302RJ2007PLC024029

Toll Free : 1800 258 5555  08003 444 888  facebook.com/ResonanceEdu  twitter.com/ResonanceEdu  www.youtube.com/resowatch  blog.resonance.ac.in

10. Which of the following option correctly describes the variation of the speed v and acceleration 'a' of a point mass falling vertically in a viscous medium that applies a force $F = -kv$, where 'k' is constant, on the body ?(Graphs are schematic and not drawn to scale)

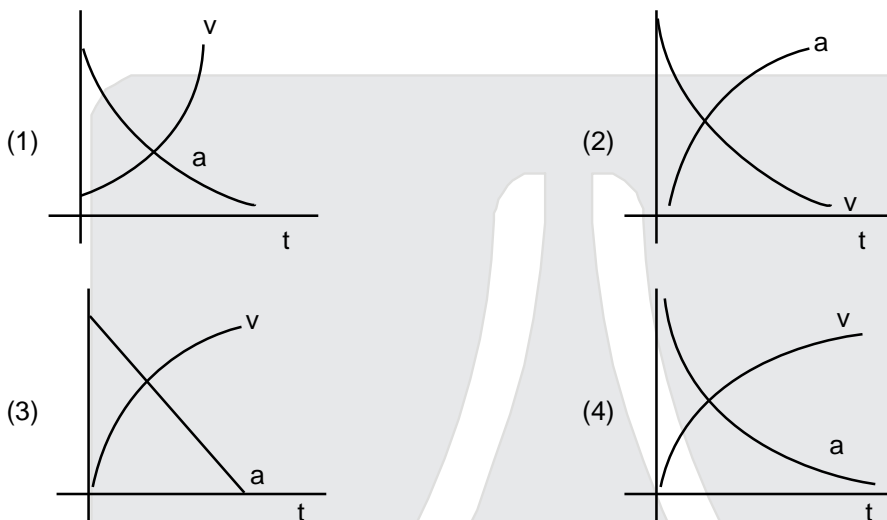

Ans. (4)

Sol. $a = g - \alpha v$

$$\frac{dv}{dt} = g - \alpha v$$

$$\int_0^v \frac{dv}{g - \alpha v} = \int_0^t dt \Rightarrow \ln\left(\frac{g - \alpha v}{g}\right) = -\alpha t$$

$$V = v_0 (1 - e^{-\alpha t}), a = \frac{dv}{dt} = v_0 \alpha e^{-\alpha t} = a_0 e^{-\alpha t}$$

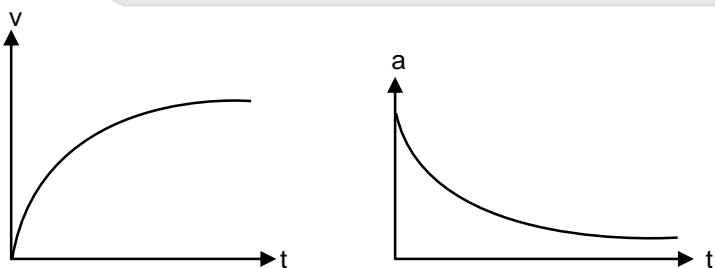

RESONANCE EDUVENTURES LTD.

CORPORATE OFFICE : CG TOWER, A-46 & 52, IPIA, NEAR CITY MALL, JHALAWAR ROAD, KOTA (RAJ.) - 324005

REG. OFFICE : J-2, JAWAHAR NAGAR, MAIN ROAD, KOTA (RAJ.)-324005 | PH. NO.: +91-744-3192222 | FAX NO. : +91-022-39167222

PH.NO. : +91-744-3012222, 6635555 | TO KNOW MORE : SMS RESO AT 56677

WEBSITE : WWW.RESONANCE.AC.IN | E-MAIL : CONTACT@RESONANCE.AC.IN | CIN : U80302RJ2007PLC024029

Toll Free : 1800 258 5555 08003 444 888 facebook.com/ResonanceEdu twitter.com/ResonanceEdu www.youtube.com/resowatch blog.resonance.ac.in

11. A series LR circuit is connected to a voltage source with $V(t) = V_0 \sin \Omega t$. After very large time current $I(t)$ behaves as $\left(t_0 \gg \frac{L}{R}\right)$:

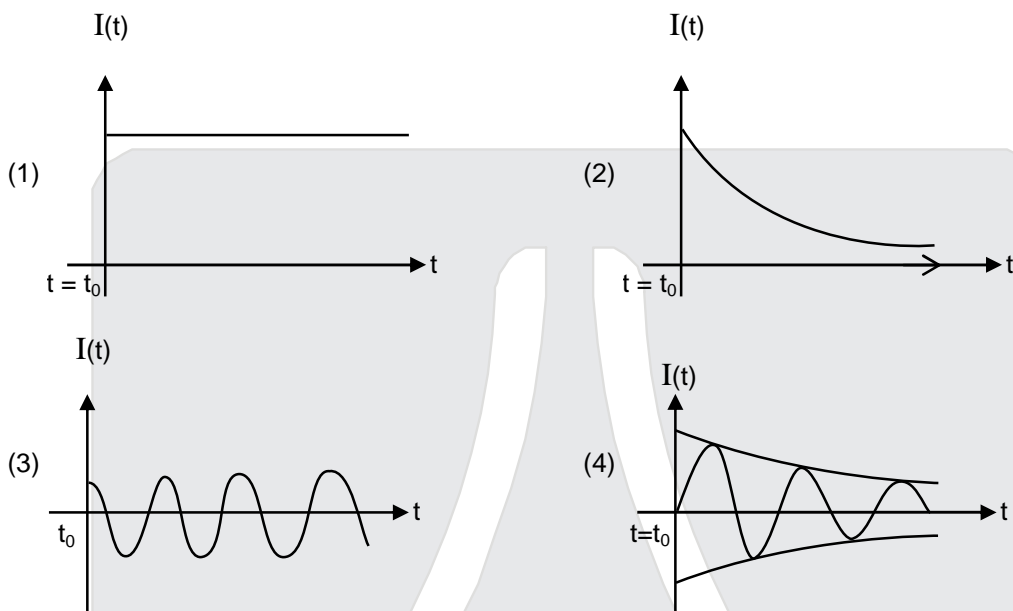

Ans. (3)
Sol. Current will be in the form of
 $I = I_0 \sin (\Omega t - \phi)$
Graph will be sinusoidal

12. A car of weight W is on an inclined road that rises by 100 m over a distance of 1 km and applies a constant frictional force $\frac{W}{20}$ on the car. While moving uphill on the road at a speed of 10ms^{-1} , the car needs power P . If it needs power $\frac{P}{2}$ while moving downhill at speed v then value of v is :

Ans. (4)
(1) 5ms^{-1} (2) 20ms^{-1} (3) 10ms^{-1} (4) 15ms^{-1}

Sol. While going up
 $(\sin \theta = \tan \theta = \frac{1}{10})$

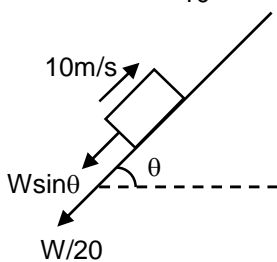

RESONANCE EDUVENTURES LTD.

CORPORATE OFFICE : CG TOWER, A-46 & 52, IPIA, NEAR CITY MALL, JHALAWAR ROAD, KOTA (RAJ.) - 324005

REG. OFFICE : J-2, JAWAHAR NAGAR, MAIN ROAD, KOTA (RAJ.)-324005 | PH. NO.: +91-744-3192222 | FAX NO. : +91-022-39167222

PH.NO. : +91-744-3012222, 6635555 | TO KNOW MORE : SMS RESO AT 56677

WEBSITE : WWW.RESONANCE.AC.IN | E-MAIL : CONTACT@RESONANCE.AC.IN | CIN : U80302RJ2007PLC024029

Toll Free : 1800 258 5555 | 08003 444 888 | [facebook.com/ResonanceEdu](https://www.facebook.com/ResonanceEdu) | twitter.com/ResonanceEdu | www.youtube.com/resowatch | blog.resonance.ac.in

$$W \sin \theta \cdot 10 + \frac{W}{20} \cdot 10 = P$$

$$\frac{3W}{2} = P$$

While going down

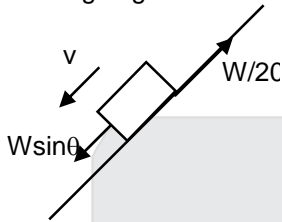

$$\frac{W}{20} v = \frac{P}{2} = \frac{3W}{4}$$

$$v = 15 \text{ m/s}$$

13. A rocket is fired vertically from the earth with an acceleration of $2g$, where g is the gravitational acceleration. On an inclined plane inside the rocket, making an angle θ with the horizontal, a point object of mass m is kept. The minimum coefficient of friction μ_{\min} between the mass and the inclined surface such that the mass does not move is :

- (1) $\tan \theta$ (2) $\tan 2\theta$ (3) $3 \tan \theta$ (4) $2 \tan \theta$.

Ans. (1)

Sol. $g_{\text{eff}} = 3g$ but $\mu_{\min} = \tan \theta$

14. Two engines pass each other moving in opposite directions with uniform speed of 30 m/s . One of them is blowing a whistle of frequency 540 Hz . Calculate the frequency heard by driver of second engine before pass each other. Speed of sound is 330 m/sec .

- (1) 540 Hz (2) 648 Hz (3) 270 Hz (4) 450 Hz

Ans. (2)

Sol.



$$f_0 = \left(\frac{330 + 30}{330 - 30} \right) 540 = 648 \text{ Hz}$$

15. The potential (in volts) of a charge distribution is given by

$$V(z) = 30 - 5z^2 \text{ for } |z| \leq 1 \text{ m}$$

$$V(z) = 35 - 10|z| \text{ for } |z| \geq 1 \text{ m}.$$

$V(z)$ does not depend on x and y . If this potential is generated by a constant charge per unit volume ρ_0 , (in units of ϵ_0) which is spread over certain region, then choose the correct statement.

- (1) $\rho_0 = 40 \epsilon_0$ in the entire region
 (2) $\rho_0 = 20 \epsilon_0$ in the entire region
 (3) $\rho_0 = 20 \epsilon_0$ for $|z| \leq 1 \text{ m}$ and $\rho_0 = 0$ elsewhere
 (4) $\rho_0 = 10 \epsilon_0$ for $|z| \leq 1 \text{ m}$ and $\rho_0 = 0$ elsewhere

Ans. (4)

RESONANCE EDUVENTURES LTD.

CORPORATE OFFICE : CG TOWER, A-46 & 52, IPIA, NEAR CITY MALL, JHALAWAR ROAD, KOTA (RAJ.) - 324005

REG. OFFICE : J-2, JAWAHAR NAGAR, MAIN ROAD, KOTA (RAJ.)-324005 | PH. NO.: +91-744-3192222 | FAX NO. : +91-022-39167222

PH.NO. : +91-744-3012222, 6635555 | TO KNOW MORE : SMS RESO AT 56677

WEBSITE : WWW.RESONANCE.AC.IN | E-MAIL : CONTACT@RESONANCE.AC.IN | CIN : U80302RJ2007PLC024029

Toll Free : 1800 258 5555 | WhatsApp : 08003 444 888 | Facebook : [facebook.com/ResonanceEdu](https://www.facebook.com/ResonanceEdu) | Twitter : twitter.com/ResonanceEdu | YouTube : www.youtube.com/resowatch | Blog : blog.resonance.ac.in

Sol.
$$E = \begin{cases} 10z \text{ v/m} & |z| \leq 1\text{m} \\ 10 \text{ v/m} & |z| \geq 1\text{m} \end{cases}$$

If should be for a sheet lying in x-y plane of thickness $z = 2\text{m}$.

For $|z| \geq 1\text{m}$
$$E = \frac{\sigma}{2\epsilon_0} = \frac{\rho(z)}{2\epsilon_0} = \frac{\rho}{\epsilon_0} = 10 \Rightarrow P = 10\epsilon_0$$

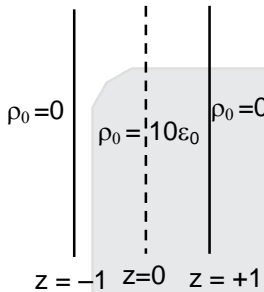

16. An audio signal consists of two distinct sound : one a human speech signal in the frequency band of 200 Hz to 2700 Hz, while the other is a high frequency music signal in the frequency band of 10200 Hz to 15200 Hz. The ratio of the AM signal band width required to send both the signals together to the AM signal band width required to send just the human speech is :

- (1) 6 (2) 5 (3) 3 (4) 2

Ans. (1)

Sol. Band width for both signals 15200 Hz – 200 Hz = 15000 Hz
Band width for human speech 2700 Hz – 200 Hz = 2500 Hz

The ratio = $\frac{15000}{2500} = 6$

17. A convex lens, of focal length 30cm, a concave lens of focal length 120 cm, and a plane mirror are arranged as shown. For an object kept at a distance of 60 cm from the convex lens, the final image, formed by the combination, is a real image, at a distance of :

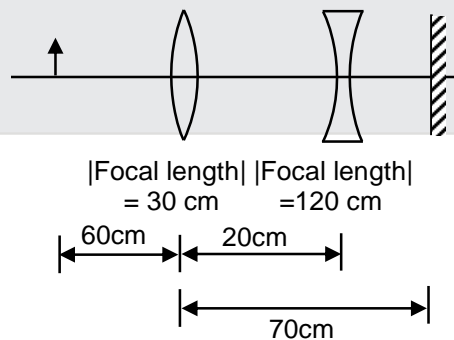

- (1) 70 cm from the concave lens (2) 60 cm from the convex lens
(3) 60 cm from the concave lens (4) 70 cm from the convex lens

Ans. [BONUS]

RESONANCE EDUVENTURES LTD.

CORPORATE OFFICE : CG TOWER, A-46 & 52, IPIA, NEAR CITY MALL, JHALAWAR ROAD, KOTA (RAJ.) - 324005

REG. OFFICE : J-2, JAWAHAR NAGAR, MAIN ROAD, KOTA (RAJ.)-324005 | PH. NO.: +91-744-3192222 | FAX NO. : +91-022-39167222

PH.NO. : +91-744-3012222, 6635555 | TO KNOW MORE : SMS RESO AT 56677

WEBSITE : WWW.RESONANCE.AC.IN | E-MAIL : CONTACT@RESONANCE.AC.IN | CIN : U80302RJ2007PLC024029

Toll Free : 1800 258 5555 08003 444 888 facebook.com/ResonanceEdu twitter.com/ResonanceEdu www.youtube.com/resowatch blog.resonance.ac.in

Sol.

$$f_1 = +30\text{cm} \quad f = -120\text{cm}$$

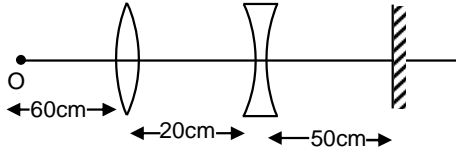

Event -1 Refraction from convex lens.

$$f = +30$$

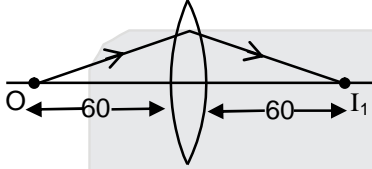

$$\frac{1}{v} - \frac{1}{-60} = \frac{1}{30}$$

$$v = +60\text{ cm}$$

Event -2 Refraction from concave lens

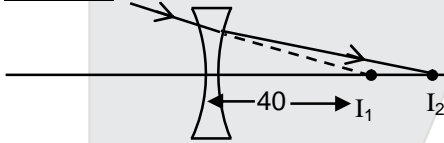

$$\frac{1}{v} - \frac{1}{+40} = \frac{1}{-120}$$

$$v = +60\text{cm}$$

Event -3 Refraction from plane mirror

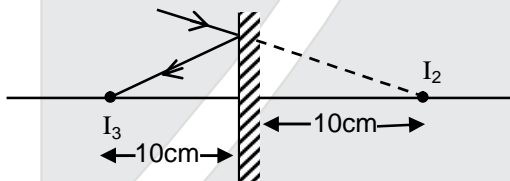

Event -4 Refraction from concave lens

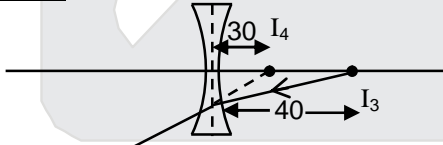

$$\frac{1}{v} - \frac{1}{-40} = \frac{1}{-120}$$

$$v = -30$$

Event -5 Refraction from convex lens

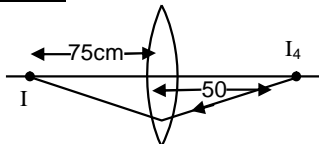

$$\frac{1}{v} - \frac{1}{-50} = \frac{1}{30} \quad ; \quad v = +75\text{ cm}$$

RESONANCE EDUVENTURES LTD.

CORPORATE OFFICE : CG TOWER, A-46 & 52, IPIA, NEAR CITY MALL, JHALAWAR ROAD, KOTA (RAJ.) - 324005

REG. OFFICE : J-2, JAWAHAR NAGAR, MAIN ROAD, KOTA (RAJ.)-324005 | PH. NO.: +91-744-3192222 | FAX NO. : +91-022-39167222

PH.NO. : +91-744-3012222, 6635555 | TO KNOW MORE : SMS RESO AT 56677

WEBSITE : WWW.RESONANCE.AC.IN | E-MAIL : CONTACT@RESONANCE.AC.IN | CIN : U80302RJ2007PLC024029

Toll Free : 1800 258 5555 | 08003 444 888 | [facebook.com/ResonanceEdu](https://www.facebook.com/ResonanceEdu) | twitter.com/ResonanceEdu | www.youtube.com/resowatch | blog.resonance.ac.in

18. Three capacitors each of $4\mu\text{F}$ are to be connected in such a way that the effective capacitance is $6\mu\text{F}$. This can be done by connecting them :

- (1) all in series
- (2) two in parallel and one in series
- (3) two in series and one in parallel
- (4) all in parallel

Ans. (3)

Sol.

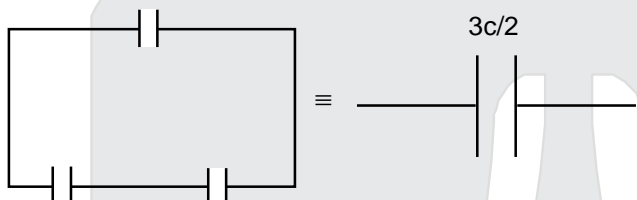

where $c = 4\mu\text{F}$

19. To know the resistance G of a galvanometer by half deflection method, a battery of emf V_E and resistance R is used to deflect the galvanometer by angle θ . If a shunt of resistance S is needed to get half deflection then G , R and S are related by the equation :

- (1) $2S = G$
- (2) $2G = S$
- (3) $S(R+G) = RG$
- (4) $2S(R+G) = RG$

Ans. (3)

Sol.

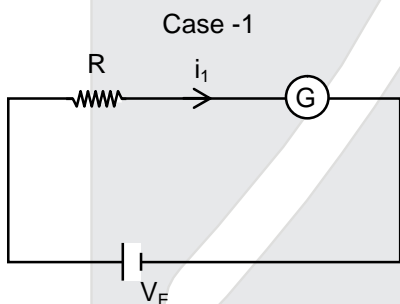

$$i_1 = \frac{V_E}{R+G}$$

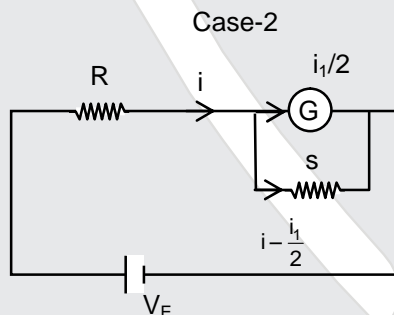

$$i = \frac{V_E}{R + \frac{GS}{G+S}}$$

$$\frac{i_1}{2} G = \left(i - \frac{i_1}{2} \right) S$$

$$i_1 (G+S) = 2 i S$$

substituting i_1 and i we get

$$S(R+G) = RG$$

RESONANCE EDUVENTURES LTD.

CORPORATE OFFICE : CG TOWER, A-46 & 52, IPIA, NEAR CITY MALL, JHALAWAR ROAD, KOTA (RAJ.) - 324005

REG. OFFICE : J-2, JAWAHAR NAGAR, MAIN ROAD, KOTA (RAJ.)-324005 | PH. NO.: +91-744-3192222 | FAX NO. : +91-022-39167222

PH.NO. : +91-744-3012222, 6635555 | TO KNOW MORE : SMS RESO AT 56677

WEBSITE : WWW.RESONANCE.AC.IN | E-MAIL : CONTACT@RESONANCE.AC.IN | CIN : U80302RJ2007PLC024029

Toll Free : 1800 258 5555 | WhatsApp : 08003 444 888 | Facebook : [facebook.com/ResonanceEdu](https://www.facebook.com/ResonanceEdu) | Twitter : twitter.com/ResonanceEdu | YouTube : www.youtube.com/resowatch | Blog : blog.resonance.ac.in

20. In the circuit shown, the resistance r is a variable resistance. If for $r = fR$, the heat generation in r is maximum then the value of f is :

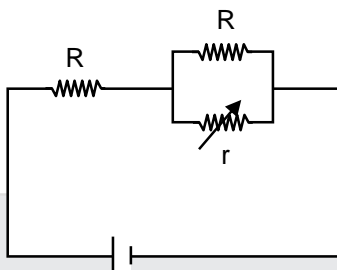

- (1) 1 (2) $\frac{3}{4}$ (3) $\frac{1}{4}$ (4) $\frac{1}{2}$

Ans. (4)

Sol.

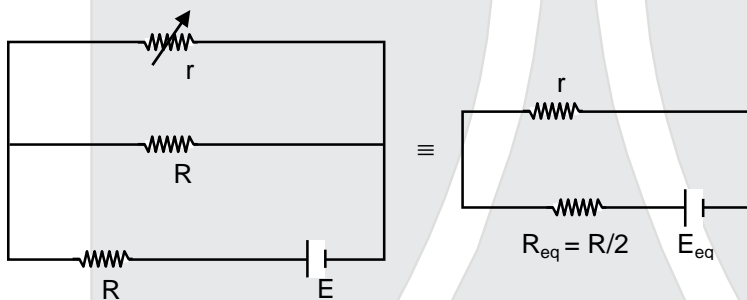

to get maximum heat generation from r .
 $r = R_{eq} = R/2$

21. A hydrogen atom makes a transition from $n = 2$ to $n=1$ and emits a photon. This photon strikes a doubly ionized lithium atom ($z = 3$) in excited state and completely removes the orbiting electron. The least quantum number for the excited state of the ion for the process is :

- (1) 4 (2) 5 (3) 2 (4) 3

Ans. (1)

Sol. Energy of proton = $13.6 - 3.4 = 10.2\text{eV}$

For removal of electron

$$10.2\text{eV} > 13.6 \frac{z^2}{n^2}$$

$$n^2 > 13.6 \frac{9}{10.2}$$

so minimum value of $n = 4$

22. 200 g water is heated from 40°C to 60°C . Ignoring the slight expansion of water, the change in its internal energy is closed to (Given specific heat of water = 4184 J/kg/K) :

- (1) 16.7 kJ (2) 167.4kJ (3) 4.2 kJ (4) 8.4 kJ

Ans. (1)

Sol. $\Delta U = mS\Delta T$

$$= \left(\frac{2}{10}\right) (4184) (20) = 16736\text{J}$$

$$= 16.7 \text{ kJ}$$

RESONANCE EDUVENTURES LTD.

CORPORATE OFFICE : CG TOWER, A-46 & 52, IPIA, NEAR CITY MALL, JHALAWAR ROAD, KOTA (RAJ.) - 324005

REG. OFFICE : J-2, JAWAHAR NAGAR, MAIN ROAD, KOTA (RAJ.)-324005 | PH. NO.: +91-744-3192222 | FAX NO. : +91-022-39167222

PH.NO. : +91-744-3012222, 6635555 | TO KNOW MORE : SMS RESO AT 56677

WEBSITE : WWW.RESONANCE.AC.IN | E-MAIL : CONTACT@RESONANCE.AC.IN | CIN : U80302RJ2007PLC024029

Toll Free : 1800 258 5555 | 08003 444 888 | [facebook.com/ResonanceEdu](https://www.facebook.com/ResonanceEdu) | twitter.com/ResonanceEdu | www.youtube.com/resowatch | blog.resonance.ac.in

23. An experiment is performed to determine the I - V characteristics of a Zener diode, which has a protective resistance of $R = 100 \Omega$, and maximum power of dissipation rating of 1W. The minimum voltage range of the DC source in the circuit is :

(1) 0 – 12V (2) 0 – 5V (3) 0 – 24 (4) 0 – 8V

Ans. (3)

Sol.

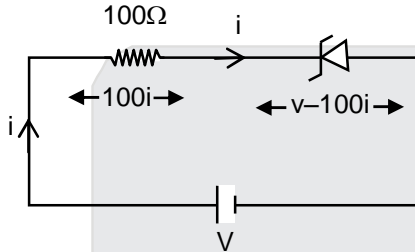

$$P_{\text{zener}} = (v-100i)i = 1$$

$$vi - 100i^2 = 1$$

$$100i^2 - vi + 1 = 0$$

i must be real

$$v^2 - 4(100) \geq 0$$

$$v \geq 20$$

24. Microwave oven acts on the principle of :

(1) giving rotational energy to water molecules
 (2) giving vibrational energy to water molecules
 (3) giving translational energy to water molecules
 (4) transferring electrons from lower to higher energy levels in water molecule

Ans. (2)

Sol. Energy of microwaves lie in range of vibration energy of water molecules.

25. A magnetic dipole is acted upon by two magnetic fields which are inclined to each other a tan angle of 75° . One of the fields has magnitude of 15mT. The dipole attains stable equilibrium at an angle 30° with this field. The magnitude of the other field (in mT) is close to :

(1) 11 (2) 1060 (3) 36 (4) 1

Ans. (1)

Sol.

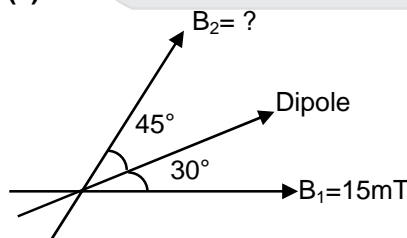

$$B_1 \sin 30^\circ = B_2 \sin 45^\circ$$

$$B_2 = \frac{B_1}{\sqrt{2}} = 10.60 \text{ mT} \approx 11\text{mT}$$

RESONANCE EDUVENTURES LTD.

CORPORATE OFFICE : CG TOWER, A-46 & 52, IPIA, NEAR CITY MALL, JHALAWAR ROAD, KOTA (RAJ.) - 324005

REG. OFFICE : J-2, JAWAHAR NAGAR, MAIN ROAD, KOTA (RAJ.)-324005 | PH. NO.: +91-744-3192222 | FAX NO. : +91-022-39167222

PH.NO. : +91-744-3012222, 6635555 | TO KNOW MORE : SMS RESO AT 56677

WEBSITE : WWW.RESONANCE.AC.IN | E-MAIL : CONTACT@RESONANCE.AC.IN | CIN : U80302RJ2007PLC024029

Toll Free : 1800 258 5555 | 08003 444 888 | [facebook.com/ResonanceEdu](https://www.facebook.com/ResonanceEdu) | twitter.com/ResonanceEdu | www.youtube.com/resowatch | blog.resonance.ac.in

26. A 50Ω resistance is connected to a battery of 5V. A galvanometer of resistance 100Ω is to be used as ammeter to measure current through the resistance, for this a resistance r_s is connected to the galvanometer. Which of the following connections should be employed if the measured current is within 1% of the current without the ammeter in the circuit ?

- (1) $r_s = 0.5\Omega$ in parallel with the galvanometer
- (2) $r_s = 0.5\Omega$ in series with the galvanometer
- (3) $r_s = 1\Omega$ in series with galvanometer
- (4) $r_s = 1\Omega$ in parallel with galvanometer

Ans. (1)

Sol. Its clear, shunt should be applied in parallel and least the shunt resistance, better the ammeter is.

27. When photons of wavelength λ_1 , are incident on an isolated sphere, the corresponding stopping potential is found to be V. When photons of wavelength λ_2 , are used, the corresponding stopping potential was thrice that of the above value. If light of wavelength λ_3 , is used then find the stopping potential for this case

$$(1) \frac{hc}{e} \left[\frac{1}{\lambda_3} + \frac{1}{2\lambda_2} - \frac{3}{2\lambda_1} \right]$$

$$(2) \frac{hc}{e} \left[\frac{1}{\lambda_3} + \frac{1}{\lambda_2} - \frac{1}{\lambda_1} \right]$$

$$(3) \frac{hc}{e} \left[\frac{1}{\lambda_3} + \frac{1}{2\lambda_2} - \frac{1}{\lambda_1} \right]$$

$$(4) \frac{hc}{e} \left[\frac{1}{\lambda_3} - \frac{1}{\lambda_2} - \frac{1}{\lambda_1} \right]$$

Ans. (1)

Sol. $eV = \frac{hc}{\lambda_1} - \phi_0$

$$3eV = \frac{hc}{\lambda_2} - \phi_0$$

$$eV' = \frac{hc}{\lambda_3} - \phi_0$$

using these equations $V' = \frac{hc}{e} \left(\frac{1}{\lambda_3} + \frac{1}{2\lambda_2} - \frac{3}{2\lambda_1} \right)$

28. In the following 'I' refers to current and other symbols have their usual meaning choose the option that corresponds to the dimensions of electrical conductivity :

- (1) $M^{-1} L^{-3} T^3 I^2$
- (2) $M^{-1} L^3 T^3 I$
- (3) $ML^{-3} T^{-3} I^2$
- (4) $M^{-1} L^{-3} T^3 I$

Ans. (1)

Sol. $J = \sigma E$

$$\sigma = \frac{J}{E} = \frac{I^1 L^{-2}}{M^1 L^1 T^{-2}}$$

$$\sigma = M^{-1} L^{-3} T^3 I^2$$

RESONANCE EDUVENTURES LTD.

CORPORATE OFFICE : CG TOWER, A-46 & 52, IPIA, NEAR CITY MALL, JHALAWAR ROAD, KOTA (RAJ.) - 324005

REG. OFFICE : J-2, JAWAHAR NAGAR, MAIN ROAD, KOTA (RAJ.)-324005 | PH. NO.: +91-744-3192222 | FAX NO. : +91-022-39167222

PH.NO. : +91-744-3012222, 6635555 | TO KNOW MORE : SMS RESO AT 56677

WEBSITE : WWW.RESONANCE.AC.IN | E-MAIL : CONTACT@RESONANCE.AC.IN | CIN : U80302RJ2007PLC024029

Toll Free : 1800 258 5555 | 08003 444 888 | facebook.com/ResonanceEdu | twitter.com/ResonanceEdu | www.youtube.com/resowatch | blog.resonance.ac.in

29. Consider a water jar of radius R that has water filled up to height H and is kept on a stand of height h (see figure). Through a hole of radius r ($r \ll R$) at its bottom, the water leaks out and the stream of water coming down towards the ground has a shape like a funnel as shown in the figure. If the radius of the cross-section of water stream when it hits the ground is x . Then :

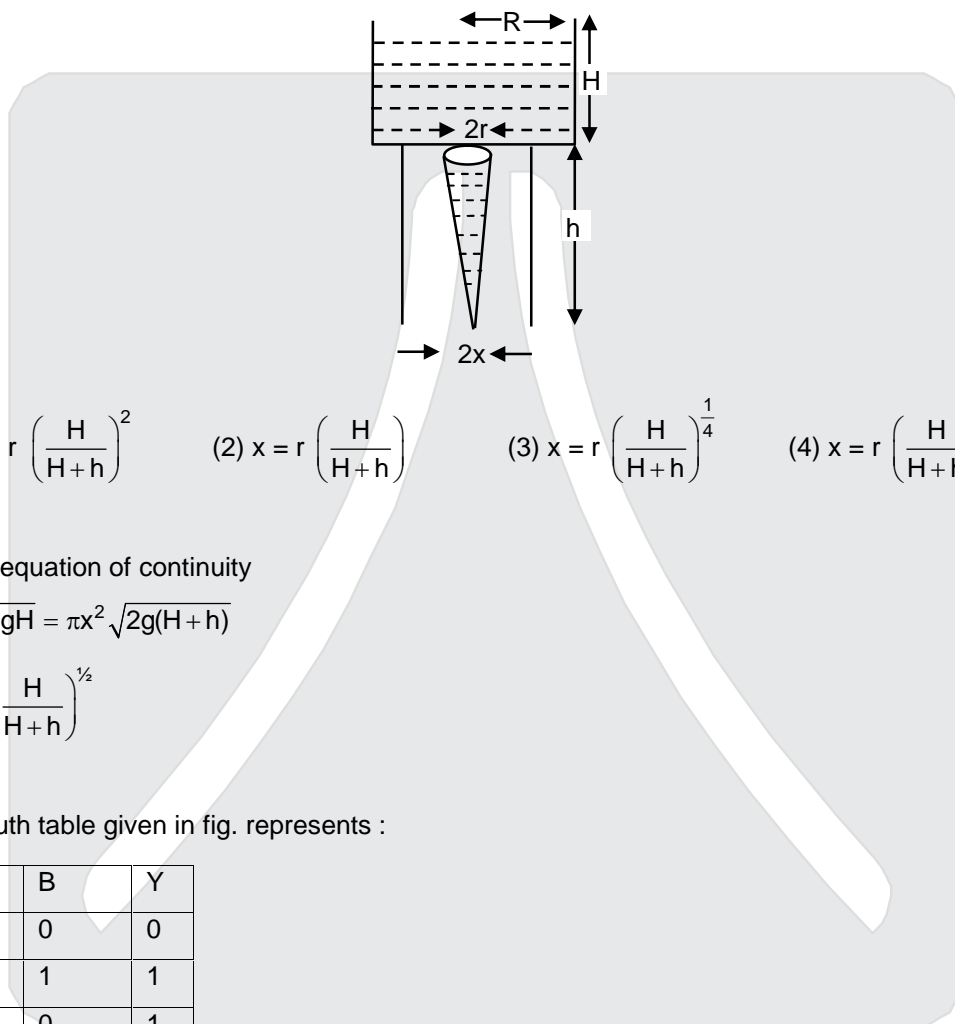

(1) $x = r \left(\frac{H}{H+h} \right)^2$ (2) $x = r \left(\frac{H}{H+h} \right)$ (3) $x = r \left(\frac{H}{H+h} \right)^{\frac{1}{4}}$ (4) $x = r \left(\frac{H}{H+h} \right)^{\frac{1}{2}}$

Ans. (4)

Sol. Using equation of continuity

$$\pi r^2 \sqrt{2gH} = \pi x^2 \sqrt{2g(H+h)}$$

$$x = r \left(\frac{H}{H+h} \right)^{\frac{1}{2}}$$

30. The truth table given in fig. represents :

A	B	Y
0	0	0
0	1	1
1	0	1
1	1	1

- (1) AND - Gate
(2) OR - Gate
(3) NOR - Gate
(4) NAND – Gate

Ans. (2)

Sol. from truth table its clear.

RESONANCE EDUVENTURES LTD.

CORPORATE OFFICE : CG TOWER, A-46 & 52, IPIA, NEAR CITY MALL, JHALAWAR ROAD, KOTA (RAJ.) - 324005

REG. OFFICE : J-2, JAWAHAR NAGAR, MAIN ROAD, KOTA (RAJ.)-324005 | PH. NO.: +91-744-3192222 | FAX NO. : +91-022-39167222

PH.NO. : +91-744-3012222, 6635555 | TO KNOW MORE : SMS RESO AT 56677

WEBSITE : WWW.RESONANCE.AC.IN | E-MAIL : CONTACT@RESONANCE.AC.IN | CIN : U80302RJ2007PLC024029

Toll Free : 1800 258 5555 | 08003 444 888 | [facebook.com/ResonanceEdu](https://www.facebook.com/ResonanceEdu) | twitter.com/ResonanceEdu | www.youtube.com/resowatch | blog.resonance.ac.in

Announces

VIVEK

A COMPACT COURSE (CC) of 5 WEEKS*

Short-term Classroom Contact Program (SCCP)

Target: JEE (Advanced) 2016

Compact
with Impact...



Target	Duration	Commencement Date/(Day)	End Date/(Day)
JEE (Advanced) 2016	05 Weeks*	07.04.2016 (Thursday)	14.05.2016 (Saturday)